

the condensation product. With cesium fluoride as catalyst, the aldol products were found to be accompanied by appreciable quantities of their OSiMe₃ derivatives. Such trimethylsilyl group transfers were limited to this fluoride ion source.

One advantage offered by the lower molecular weight carbonyl reagents is their volatility. Thus, they could be initially introduced in multiple molar equivalents and the excess subsequently removed during solvent evaporation. Self-condensation was not troublesome.

The reaction of ketone **15** with aldehydes in the presence of BTAF was next examined. In this instance, initially formed enolate ion **16** could experience prototropic shift to give **17** prior to electrophilic capture. In the presence of 2.4 equiv of benzaldehyde, **18** proved to be the major (and on occasion the sole) product (58-63% isolated). The amounts of **19** produced were

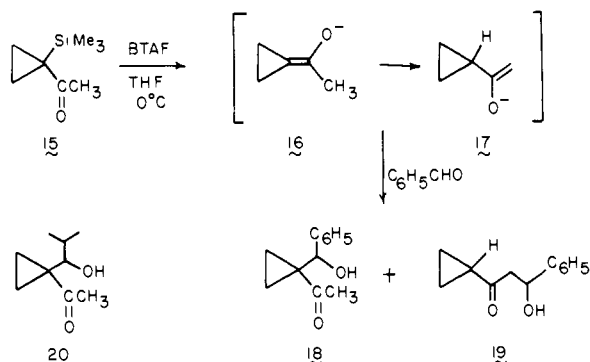

widely variable ranging from 0% to 19%. Thus, proton transfer is not a serious side reaction. In a single experiment involving isobutyraldehyde, **20** was the only aldol product isolated (27%). No effort was made in either case to recover the volatile cyclopropyl methyl ketone.

The serviceable behavior of **15** prompted study of the more extended systems **21**¹⁹ and **25**.¹⁶ Although the enolates obtained by desilylation (BTAF) of these substrates are certain to be less reactive due to enhanced charge delocalization, they entered usefully into aldol condensation. For example, the conversion of **21** to **22** proceeded in 73% yield. An increase in steric bulk as with isobutyraldehyde led to a lower yield of aldol (**23**, 27%); the protonated product **24** (70%) was dominant. Under the same conditions, **25** was transformed in the presence of benzaldehyde

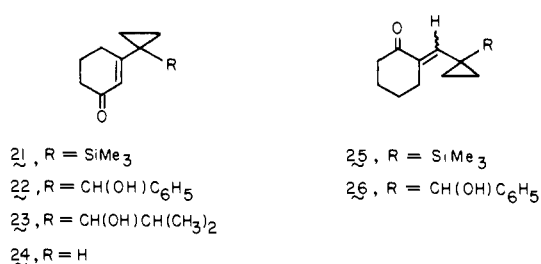

to **26** (45%). The high regioselectivity of these alkylations is noteworthy.

The yields described herein have not been maximized. Nonetheless, in situ removal of an α -SiMe₃ group from an electronegatively substituted three-membered ring is seen to be operationally well suited to preparative cyclopropyl carbanion generation. This protocol offers considerable flexibility for basing new synthetic strategies on these intermediates. Understandably, success will be improved if the electrophilic partner is relatively inert toward direct reaction with F⁻ at 0 °C for short time periods.

Acknowledgment. We gratefully acknowledge support of this work by the National Science Foundation.

(19) Paquette, L. A.; Wells, G. J.; Horn, K. A.; Yan, T.-H. *Tetrahedron* 1983, 39, 913.

Cyclization of (1-Methyl-5-hexenyl)sodium in Ethers

John F. Garst* and John B. Hines, Jr.

Department of Chemistry, The University of Georgia
Athens, Georgia 30602

Received July 13, 1984

Reactions of 1-methyl-5-hexenyl chloride and bromide in ethers with sodium naphthalene and sodium mirrors at room temperature and 0 °C give large amounts of *cis*- and *trans*-1,2-dimethylcyclopentanes. Table I gives results for sodium naphthalene at room temperature.

1-Methyl-5-hexenyl radicals are intermediates (Scheme I),¹ and their cyclization is well-known,⁹ but many of our *cis*/*trans* ratios are much lower than 3.8, the value for radical cyclization.^{10,11} For sodium-mirror reaction, the *cis*/*trans* ratio ranges as low as 0.32. This suggests that 1-methyl-5-hexenylsodium also cyclizes, with a *trans* preference, giving [(2-methylcyclopentyl)methyl]sodiums. Cyclizations of other 1-methyl-5-hexenyl metallics are known, and most of them show a strong *trans* preference.¹²

(1) (a) Garst, J. F.; Ayers, P. W.; Lamb, R. C. *J. Am. Chem. Soc.* 1966, 88, 4260. (b) Garst, J. F.; Barbas, J. T.; Barton, F. E., II. *J. Am. Chem. Soc.* 1968, 90, 7159. (c) Garst, J. F.; Cox, F. H.; Barbas, J. T.; Roberts, R. D.; Morris, J. I.; Morrison, R. C. *J. Am. Chem. Soc.* 1970, 92, 5761. (d) Garst, J. F. *Acc. Chem. Res.* 1971, 4, 400. (e) Garst, J. F.; Barton, F. E., II; Morris, J. E. *J. Am. Chem. Soc.* 1971, 93, 4310. (f) Garst, J. F. In "Free Radicals"; Kochi, J. K., Ed.; Wiley: New York, 1973; Vol. I, Chapter 9, pp 520-529. (g) Garst, J. F.; Barbas, J. T. *J. Am. Chem. Soc.* 1974, 96, 3239.

(2) (a) Sargent, G. D.; Cron, J. N.; Bank, S. *J. Am. Chem. Soc.* 1966, 88, 5363. (b) Sargent, G. D.; Browne, M. W. *J. Am. Chem. Soc.* 1967, 89, 2788. (c) Sargent, G. D.; Lux, G. A. *J. Am. Chem. Soc.* 1968, 90, 7160. (d) Bank, S.; Bank, J. F. *Tetrahedron Lett.* 1969, 4533. (e) Bank, S.; Bockrath, B. *J. Am. Chem. Soc.* 1971, 93, 430. (f) Bank, S.; Bockrath, B. *J. Am. Chem. Soc.* 1972, 94, 6076. (g) Bank, S.; Juckett, D. A. *J. Am. Chem. Soc.* 1975, 97, 567. (h) Bank, S.; Juckett, D. A. *J. Am. Chem. Soc.* 1976, 98, 7742. (i) Bank, S.; Bank, J. F. In "Organic Free Radicals"; Pryor, W. A., Ed.; American Chemical Society: Washington, DC, 1978; ACS Symp. Ser. No. 69, Chapter 21, pp 343-358.

(3) (a) Mazeleyrat, J. P.; Welvart, Z. *Chem. Commun.* 1972, 547. (b) Mazeleyrat, J. P.; Welvart, Z. *J. Am. Chem. Soc.* 1977, 99, 6933.

(4) (a) Walborsky, H. M.; Young, A. E. *J. Am. Chem. Soc.* 1964, 86, 3288. (b) Walborsky, H. M.; Banks, R. B. *Bull. Soc. Chim. Belg.* 1980, 89, 849. (c) Walborsky, H. M. *Tetrahedron* 1981, 37, 1625.

(5) (a) Bodewitz, H. S. H. J.; Blomberg, C.; Bickelhaupt, F. *Tetrahedron Lett.* 1972, 251. (b) Bodewitz, H. W. H. J.; Blomberg, C.; Bickelhaupt, F. *Tetrahedron* 1973, 29, 719. (c) Bodewitz, H. W. H. J.; Blomberg, C.; Bickelhaupt, F. *Tetrahedron* 1975, 31, 1053. (d) Schaart, B. J.; Bodewitz, H. W. H. J.; Blomberg, C.; Bickelhaupt, F. *J. Am. Chem. Soc.* 1976, 98, 3712. (e) Bodewitz, H. W. H. J.; Schaart, B. J.; Van der Niet, J. D.; Blomberg, C.; Bickelhaupt, F. *Tetrahedron* 1978, 34, 2523.

(6) (a) Rogers, H. R.; Hill, C. L.; Fujiwara, Y.; Rogers, R. J.; Mitchell, H. L.; Whitesides, G. M. *J. Am. Chem. Soc.* 1980, 102, 217. (b) Rogers, H. R.; Deutch, J.; Whitesides, G. M. *J. Am. Chem. Soc.* 1980, 102, 226. (c) Rogers, H. R.; Rogers, R. J.; Mitchell, H. L.; Whitesides, G. M. *J. Am. Chem. Soc.* 1980, 102, 231. (d) Barber, J. J.; Whitesides, G. M. *J. Am. Chem. Soc.* 1980, 102, 239. (e) Lawrence, L. M.; Whitesides, G. M. *J. Am. Chem. Soc.* 1980, 102, 2493. (f) Root, K. J.; Deutch, J.; Whitesides, G. M. *J. Am. Chem. Soc.* 1981, 103, 5475.

(7) (a) Dubois, J.-E.; Molle, G.; Tourillon, G.; Bauer, P. *Tetrahedron Lett.* 1979, 5069. (b) Molle, G.; Bauer, P.; Dubois, J. E. *J. Org. Chem.* 1982, 47, 4120.

(8) Garst, J. F.; Pacifici, J. A.; Felix, C. C.; Nigam, A. *J. Am. Chem. Soc.* 1978, 100, 5974.

(9) (a) Brace, N. O. *J. Org. Chem.* 1967, 32, 2711. (b) Walling, C.; Ciuffari, A. *J. Am. Chem. Soc.* 1972, 94, 6059. (c) Beckwith, A. L. J.; Blair, I.; Phillippou, G. *J. Am. Chem. Soc.* 1974, 96, 1613.

(10) The reaction of 1-methyl-5-hexenyl bromide with tributyltin hydride in DME, promoted by AIBN under fluorescent lighting at room temperature, gives 1,2-dimethylcyclopentanes with a *cis*/*trans* ratio of 3.8. The literature gives similarly determined values of about 2.7 for reactions near 70 °C.^{9a,c}

(11) Conceivably, our ratios could be even lower than indicated, making the contrast with radical cyclization even more pronounced. Methylcyclohexane is lumped with *cis*-1,2-dimethylcyclopentane in Table I. At present, we assume that it is negligible, since five-membered-ring 1-methyl-5-hexenyl cyclizations are overwhelmingly favored for both radicals and anions.^{9,12}

Table I. C₇ Products of Reductions of 1-Methyl-5-hexenyl Halides in Ethers by Sodium Naphthalene at Room Temperature^a

expt	solvent	hal	1-h	c-cyc	t-cyc	c-2-h	t-2-h	c/t-cyc
38	DME	Cl	38	12	20	16	14	0.62
39			30	17	23	9.6	20	0.77
37	THF	Br	39	34	16	5.4	5.4	2.1
33			20	22	23	17	18	0.92
35		Cl	32	30	17	10	11	1.75
34			32	31	15	8	13	2.05
32			19	56	20	1.8	3.4	2.8

^aRelative yields of tabulated products. Reactions were conducted, as described previously,¹⁸ by injecting alkyl halides into sodium naphthalene solutions. Typical yields of C₇ hydrocarbons are ca. 30%. Other likely products are alkylated naphthalene derivatives and C₁₄ hydrocarbons (alkyl dimers). Analyses were by VPC.

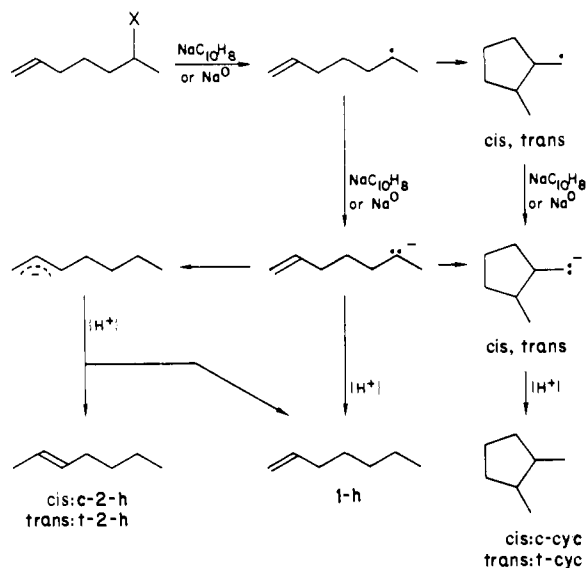
Scheme I^a

^a Sodium and halide ions are omitted. States of ionic aggregation are unknown; no particular states are implied.

Since significant reaction takes place during mixing, sodium naphthalene-alkyl halide reactions cannot be controlled easily, and no attempt to do so was made. Consequently, there was considerable variation in the 1,2-dimethylcyclopentane cis/trans ratio. A correlation (Figure 1) of the observed ratios with the yields of 2-heptenes supports the hypothesis that (1-methyl-5-hexenyl)sodium cyclizes. 2-Heptenes are formed from (1-methyl-5-hexenyl)sodium through an intramolecular 1,4-proton transfer that competes with cyclization (Scheme I).⁸ The assumption that the ratio of the extents of 1,4-proton transfer and cyclization is constant leads to the following equation:

$$y = r/(1+r) - [g(r-a)/((1+a)(1+r))]x$$

where y is the fraction of the 1,2-dimethylcyclopentanes that is cis, r is the cis/trans ratio for cyclizations of the 1-methyl-5-hexenyl radical, g is the ratio of yields (1,2-dimethylcyclopentanes from anion cyclization)/(2-heptenes), a is the cis/trans ratio for cyclizations of (1-methyl-5-hexenyl)sodium, and x is the ratio of yields (2-heptenes)/(1,2-dimethylcyclopentanes).

The line in Figure 1 is drawn with intercept 0.79, the value of $r/(1+r)$ for $r = 3.8$. Even though the data are for two halogens and two solvents, they conform to the predicted equation.

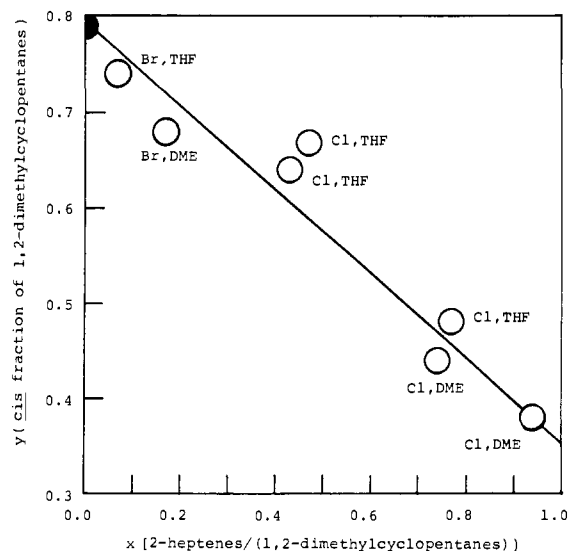

Figure 1. Correlation of the cis fraction of 1,2-dimethylcyclopentanes with yield of 2-heptenes; see text for the relevant equation and meanings of symbols. The solid point at (0,0.79) represents 100% radical cyclization.¹⁰

1-Methyl-5-hexenyl and related cyclizations have been used widely as probes for radical reaction intermediates.^{1,13,14} When anion cyclization is negligible, these probes are especially valuable; they can be applied where alkyl anions are possible alternative or additional intermediates.¹ However, when anion cyclization occurs and cannot be distinguished from radical cyclization, the usefulness of the probe is severely limited. Fortunately, cyclizations of 1-methyl-5-hexenyl anions and radicals can be distinguished, since they occur with different cis/trans ratios and since products of anion cyclizations are accompanied by those of 1,4-proton shifts.

In applying the 1-methyl-5-hexenyl probe to reactions of alkyl halides with (trimethyltin)sodium and with lithium dialkylcuprates, Ashby and co-workers assumed that only radicals cyclize.¹⁵ Lee and San Filippo challenged this, concluding that "the formation of (2-methylcyclopentyl)methyl-derived products cannot be considered as prima facie evidence for the intermediacy of 1-methyl-5-hexenyl radicals".¹⁶ Our results show that Lee and San Filippo are correct but that anion and radical cyclizations can be sorted out from cis/trans ratios. The cis/trans ratios from reactions of 1-methyl-5-hexenyl halides with (trimethyltin)sodium (revised: ~ 4.5 at 0 °C)^{15c} are consistent with 100% radical cyclization.

There are apparent halogen effects on product distributions in both sodium naphthalene and sodium-mirror reactions. While there are other possible explanations, the possibility that alkyl halide anion radicals could be intermediates that undergo reactions

(12) (a) Richey, H. G., Jr.; Rees, T. C. *Tetrahedron Lett.* **1966**, 4297. (b) Kossa, W. C.; Rees, T. C.; Richey, H. G., Jr. *Tetrahedron Lett.* **1971**, 3455. (c) Richey, H. G., Jr.; Veale, H. S. *Tetrahedron Lett.* **1975**, 615. (d) Drozd, V. N.; Ustynyuk, Yu. A.; Tsel'eva, M. A.; Dmitriev, L. B. *Zh. Obshch. Khim.* **1968**, 38, 2114; *J. Gen. Chem. USSR (Engl. Transl.)* **1968**, 38, 2047. (e) Drozd, U. N.; Ustynyuk, Yu. A.; Tsel'eva, M. A.; Dmitriev, L. B. *Zh. Obshch. Khim.* **1969**, 39, 1991; *J. Gen. Chem. USSR (Engl. Transl.)* **1969**, 39, 1951. (f) Stefani, A. *Helv. Chim. Acta* **1974**, 57, 1346. Other observations of 5-hexenyl metallic cyclizations include: (f) St. Denis, J.; Dolzine, T.; Oliver, J. P. *J. Am. Chem. Soc.* **1972**, 94, 8260. (g) Whitesides, G. M.; Bergbreiter, D. E.; Kendall, P. E. *J. Am. Chem. Soc.* **1974**, 96, 2806. (h) Bahl, J. J.; Bates, R. B.; Beavers, W. A.; Mills, N. S. *J. Org. Chem.* **1976**, 41, 1620.

(13) Griller, D.; Ingold, K. U. *Acc. Chem. Res.* **1980**, 13, 317.

(14) Many examples are given by: Surzur, J.-M. In "Reactive Intermediates"; Abramovitch, R. A., Ed.; Plenum Press: New York, 1982; Vol. 2, Chapter 3, pp 253-276.

(15) (a) Ashby, E. C.; DePriest, R. *J. Am. Chem. Soc.* **1982**, 104, 6145. (b) Ashby, E. C.; DePriest, R. N.; Tuncay, A.; Srivastava, S. *Tetrahedron Lett.* **1982**, 23, 5251. (c) Ashby, E. C., personal communication.

(16) Lee, K.-W.; San Filippo, J., Jr. *Organometallics* **1983**, 2, 906.

other than fragmentation to alkyl radicals and halide ions should be kept in mind.¹⁷

Acknowledgment is made to the donors of The Petroleum Research Fund, administered by the American Chemical Society, for support of this research.

Supplementary Material Available: Derivation of the equation relating cis/trans ratios of 1,2-dimethylcyclopentanes to yields of 2-heptenes and additional description of analytical procedures (2 pages). Ordering information is given on any current masthead page.

(17) Garst, J. F.; Roberts, R. D.; Pacifici, J. A. *J. Am. Chem. Soc.* 1977, 99, 3528 and references cited therein.

Paramagnetic ¹H NMR Spectra of Hemerythrin from *Phascolopsis gouldii*

Michael J. Maroney, Randall B. Lauffer,[†] and Lawrence Que, Jr.*

Department of Chemistry, University of Minnesota
Minneapolis, Minnesota 55455

Donald M. Kurtz, Jr.

Department of Chemistry, Iowa State University
Ames, Iowa 50011
Received July 9, 1984

Hemerythrin (Hr), a respiratory protein isolated from a number of marine invertebrates, has active sites consisting of binuclear iron centers.¹ Such centers may be prototypical of an emerging class of binuclear iron proteins which include porcine uteroferrin,² beef spleen purple acid phosphatase,^{2,3} and ribonucleotide reductase from *E. coli*.⁴ The binuclear cluster in hemerythrin is known to exist in three formal oxidation states: [Fe(II),Fe(II)] (deoxy); [Fe(III),Fe(II)] (semimet); [Fe(III),Fe(III)] (oxy and met).¹ From a number of physical studies including X-ray crystallography,^{1,5} a detailed description of the active site of met- and oxyhemerythrin has been developed. The high-spin ferric centers are coordinated in a facial biotetrahedron by five terminal histidines (two to one iron atom and three to the other) and by bridging oxo and carboxylate groups. The coordination site remaining on the iron atom bound by two histidine ligands is vacant in metHr and occupied by peroxide in oxyHr and by small anions in various synthetic met forms. The two iron atoms are strongly coupled antiferromagnetically ($J \sim -100 \text{ cm}^{-1}$)⁶—a property associated with the ferric oxidation state and the oxo bridge. Considerably less structural information is available for deoxyhemerythrin^{7,8} and the mixed-valent forms of the protein. We report here the results of a structural investigation of hemerythrin from *Phascolopsis gouldii* in the met and semimet states using ¹H NMR spectroscopy as a probe of the ligand environment and the magnetic properties of the binuclear iron active site.

The ¹H NMR spectra of metHr and metHrN₃ (Figure 1A,B) feature paramagnetically shifted resonances in the 12–25 ppm region associated with solvent-exchangeable protons and a resonance at 11 ppm associated with nonexchangeable protons. A previous NMR study of this protein failed to observe such fea-

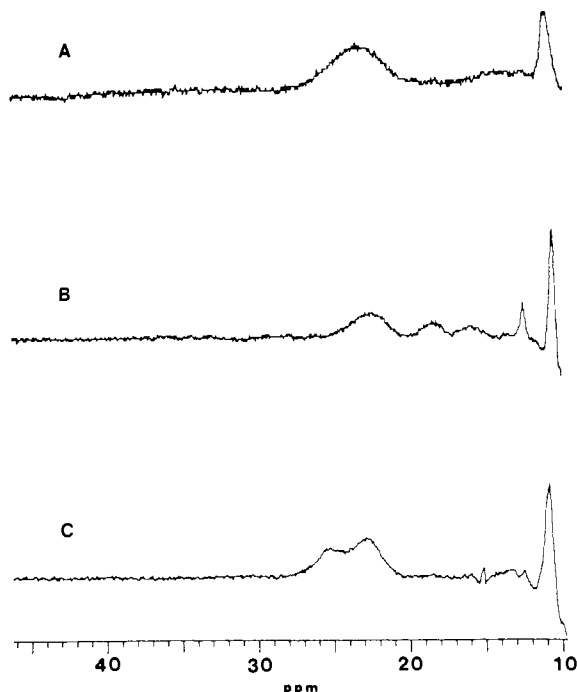

Figure 1. ¹H NMR spectra of methemerythrins in 50 mM phosphate buffer, pH 7.5, at 30 °C. (A) 4 mM metHr with added 50 mM NaClO₄ (300 MHz). (B) 4 mM metHrN₃ (300 MHz). (C) 4 mM metHrS (360 MHz). All spectra were obtained on Nicolet NT-300 and NT-360 spectrometers under conditions described in ref 10.

tures,⁹ due to their relative broadness and the use of 75% D₂O as solvent. The exchangeable resonances are assigned to the NH protons of the imidazole groups on histidine ligands. These shifts are small compared to those observed for mononuclear high-spin ferric complexes, where the imidazole NH resonances are observed at $\sim 100 \text{ ppm}$.¹⁰ Since the proton contact shift is dependent on the magnetic susceptibility of the center to which it is attached,¹¹ the decreased shift observed for these protons in the metHr complexes is consistent with a high degree of antiferromagnetic coupling between the iron atoms. The resonance at 11 ppm is assigned to the β - and γ -CH₂ protons of the bridging aspartate and glutamate, respectively. This assignment is consistent with the methyl resonance for bridging acetate ligands observed at 10.5 ppm in [Fe₂(HBPz₃)₂(OAc)₂O].^{12,13} A spectrum obtained for oxyHr closely resembles that of metHrN₃.

The spectrum obtained for metHrS (Figure 1C), where the oxo bridge is believed to have been replaced by a sulfido bridge,¹⁴ exhibits two broad peaks associated with exchangeable protons at 23 and 25 ppm and one at 11 ppm that is nonexchangeable. The similarity of this spectrum to those of the other met forms demonstrates that the coupling between the iron atoms in the met-sulfido complex is also large and indicates that the sulfido bridge is nearly as effective as the oxo group in mediating the antiferromagnetic interaction. The slightly larger shifts observed for the met-sulfido complex are consistent with the somewhat weaker coupling observed for [Fe(salen)]₂S ($J = -75 \text{ cm}^{-1}$)¹⁵ when compared to that for [Fe(salen)]₂O ($J = -95 \text{ cm}^{-1}$).¹⁶

[†] Cornell University.

(1) (a) Wilkins, R. G.; Harrington, P. C. *Adv. Inorg. Biochem.* 1983, 5, 51–85. (b) Klotz, I. M.; Kurtz, D. M., Jr. *Acc. Chem. Res.* 1984, 17, 16–22. (c) Sanders-Loehr, J.; Loehr, T. M. *Adv. Inorg. Biochem.* 1979, 1, 235–252. (2) Antanaitis, B. C.; Aisen, P. *Adv. Inorg. Biochem.* 1983, 5, 111–136. (3) Que, L., Jr. *Coord. Chem. Rev.* 1983, 50, 73–108. (4) Sjöberg, B.-M.; Graslund, A. *Adv. Inorg. Biochem.* 1983, 5, 87–110. (5) Stenkamp, R. E.; Sieker, L. C.; Jensen, L. H. *J. Am. Chem. Soc.* 1984, 106, 618–622. (6) Dawson, J. W.; Gray, H. B.; Hoening, H. E.; Rossmann, G. R.; Schredder, J. M.; Wang, R. H. *Biochemistry* 1972, 11, 461–465. (7) Elam, W. T.; Stern, E. A.; McCallum, J. D.; Sanders-Loehr, J. *J. Am. Chem. Soc.* 1983, 105, 1919–1923. (8) York, J. L.; Bearden, A. J. *Biochemistry* 1970, 9, 4549–4954.

(9) York, J. L.; Millett, F. S.; Minor, L. B. *Biochemistry* 1980, 19, 2583–2588.

(10) Lauffer, R. B.; Antanaitis, B. C.; Aisen, P.; Que, L., Jr. *J. Biol. Chem.* 1983, 258, 14212–14218.

(11) Jesson, J. P. In "NMR of Paramagnetic Molecules"; LaMar, G. N., Horrocks, W. DeW., Jr., Holm, R. H., Eds.; Academic Press: New York, 1973; pp 42–44.

(12) Armstrong, W. H.; Spool, A.; Papaefthymiou, G. C.; Frankel, R. B.; Lippard, S. J. *J. Am. Chem. Soc.* 1984, 106, 3653–3667.

(13) The abbreviations used are the following: HBPz₃, hydrotris(1-pyrazolyl)borate; OAc, acetate; salen, ethylenedis(salicylidene)amine.

(14) Lukat, G. S.; Kurtz, D. M., Jr.; Shiemke, A. K.; Loehr, T. M.; Sanders-Loehr, J. *Biochemistry*, in press.

(15) Mitchell, P. C. H.; Parker, D. A. *J. Inorg. Nucl. Chem.* 1973, 35, 1385–1390.